

KOI-6002AL

Features

- Compliant to IrDA 1.4 Low Power Standard
- Wide Voltage Operation : 2.4 ~ 5.5V
- Compact Package Integrated Transmitter and Receiver (7.0L x 2.75W x 1.6T)
- Complete Power Down Mode for the Current Consumption.
- LED Stuck-high Protection
- Lead-free & High reliability package

Applications

- Cellular Phone
- Personal Computer(Desk-top PC, Lap-top PC)
- Printers, Vending Machine, ATM
- Personal Digital Assistants.(PDA)

Dimensions

(Unit : mm)

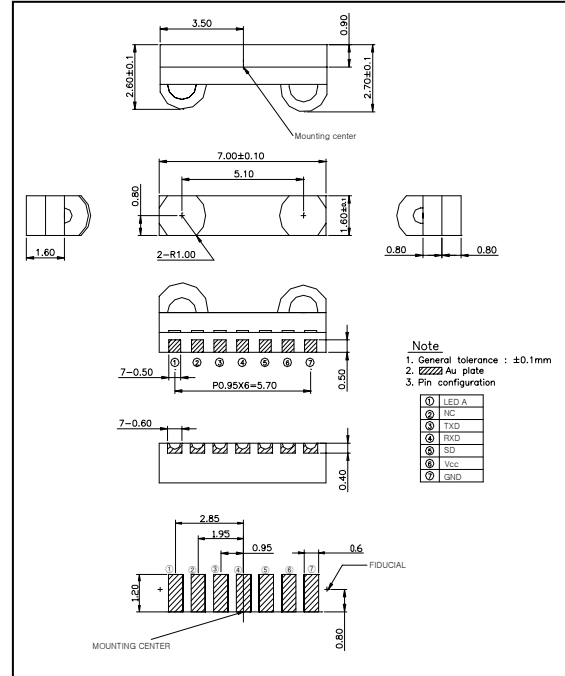

Block Diagram

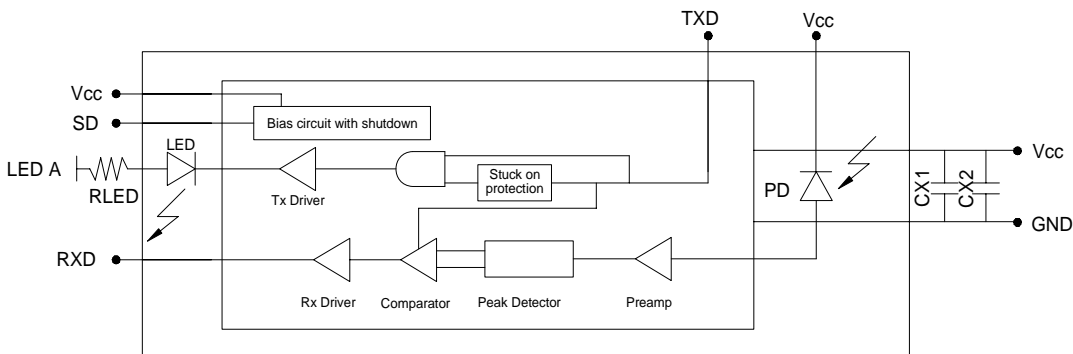

RLED 6.8Ω±5%, 0.125 Watt, LED A =2.7V
 RLED 10Ω±5%, 0.125 Watt, LED A =3.0V
 RLED 12Ω±5%, 0.125 Watt, LED A =3.6V
 RLED 16Ω±5%, 0.125 Watt, LED A =4.2V
 CX1 0.47μF±20%, Ceramic : CX2 4.7μF±20%, Tantalum
 CX1, CX2 must be placed 7mm of the KOI-6002AL

KOI-6002AL

Absolute Maximum Ratings

[Ta = 25 °C]

Parameter	Symbol	Conditions	Min.	Max.	Unit
Supply Voltage	V _{CC}	-	0	6.5	V
LED Supply Voltage	V _{LED}	-	0	6.0	V
Operating Temperature	T _{opr.}	-	-20	85	°C
Storage Temperature	T _{stg.}	-	-40	100	°C
DC LED Transmit Current	I _{LED (DC)}	-	-	50	mA
Peak LED Transmit Current	I _{LED (PK)}	<90µs pulse width, <20% duty cycle	-	200	mA
Receiver Data Output Voltage	V _{RxD}	-	-0.5	V _{CC} +0.5	V
Transmitter Data Input Voltage	V _{TxD}	-	-0.5	V _{CC} +0.5	V
Data Rate	BR	-	9.6	115.2	Kbit/s

4. Electro-Optical Characteristics

[Ta=25 °C, V_{CC}=3.3V]

Parameter	Symbol	Conditions	Min.	Typ.	Max.	Unit	
Supply Current	I _{CC1}	Shutdown	-	-	1	µA	
	I _{CC2}	Idle	-	100	200	µA	
Transmitter	Transmitter Wakeup Time	T _{tw}	-	30	200	µs	
	Viewing Angle	2θ _{1/2}	30	-	60	deg.	
	Data Output Pulse Width	T _{stp} w	tpw(RxD)=1.63µs at 115.2kbit/s	1.6	1.7	1.9	µs
	Rise Time	t _r	BR=115.2kbit/s	-	20	600	ns
	Fall Time	t _f		-	20	600	ns
	Peak Emission Wavelength	λ _p	-	-	875	-	nm
	Spectral Bandwidth	Δλ	-	-	45	-	nm
Receiver	Viewing Angle	2θ _{1/2}	30	-	-	deg.	
	Peak Sensitivity Wavelength	λ _p	-	880	-	nm	
	High Level Output Voltage	V _{OH}	I _{OH} =-200 µA	2/3 V _{CC}	-	V _{CC}	V
	Low Level Output Voltage	V _{OL}	I _{OL} =200 µA	-	-	1/3 V _{CC}	V
	Rx SIR Pulse Width	T _{srp} w	tpw(RxD)=1.63µs at 115.2kbit/s	1	2.2	4	µs
	Rise Time	t _r	BR=115.2kbit/s	-	80	600	ns
	Fall Time	t _f		-	40	600	ns
	Communication Distance	D		20	100	-	cm
	Receiver Latency Time	TL		-	100	150	µs
Receiver Wakeup Time	T _{rw}		-	150	200	µs	