

KOI-6002A(E)

Features

- Compliant to IrDA 1.4 Low Power Standard
- Wide Voltage Operation : 2.4 ~ 3.6V
- Compact Package Integrated Transmitter and Receiver (7.0L x 2.7W x 1.6T)
- Complete Power Down Mode for the Current Consumption.
- LED Stuck-high Protection
- Typical link distance > 60cm
- Lead-free & High reliability package

Applications

- Cellular Phone
- Personal Computer(Desk-top PC, Lap-top PC)
- Printers, Vending Machine, ATM
- Personal Digital Assistants.(PDA)

Dimensions

(Unit : mm)

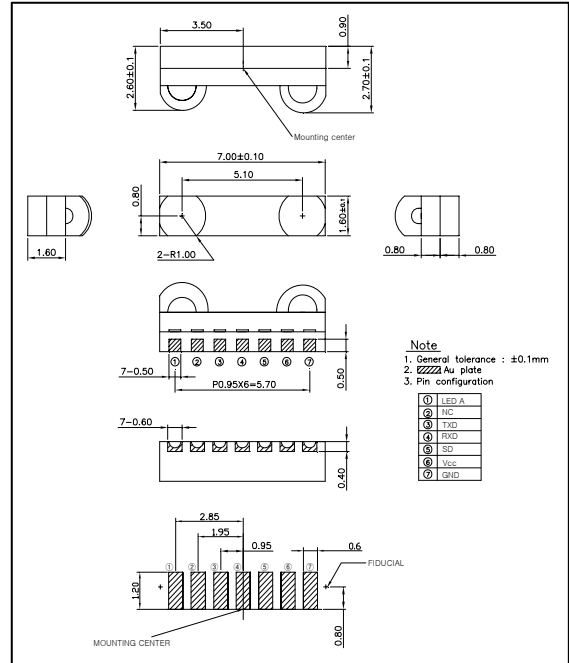

Block Diagram

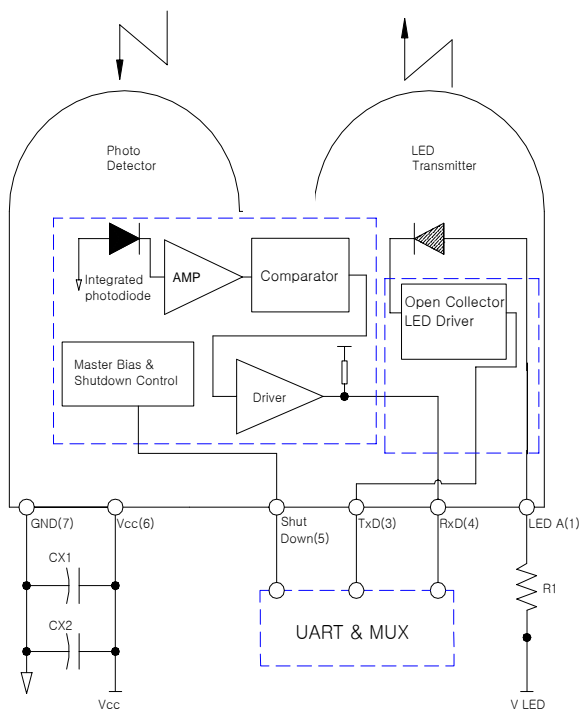

KOI-6002A(E)

Absolute Maximum Ratings

[Ta = 25 °C]

Parameter	Symbol	Conditions	Min.	Max.	Unit
Supply Voltage	V _{CC}	-	0	7.0	V
LED Supply Voltage	V _{LED}	-	0	7.0	V
Operating Temperature	T _{opr.}	-	-20	85	°C
Storage Temperature	T _{stg.}	-	-40	100	°C
DC LED Transmit Current	I _{LED} (DC)	-	-	75	mA
Peak LED Transmit Current	I _{LED} (PK)	<90µs pulse width, <20% duty cycle	-	300	mA
Receiver Data Output Voltage	V _{RxD}	-	-0.5	V _{CC} +0.5	V
Transmitter Data Input Voltage	V _{TxD}	-	-0.5	V _{CC} +0.5	V
Data Rate	BR	-	9.6	115.2	Kbit/s

4. Electro-Optical Characteristics

[Ta=25 °C, V_{CC}=3.3V]

Parameter	Symbol	Conditions	Min.	Typ.	Max.	Unit	
Supply Current	I _{CC1}	Shutdown	-	0.001	0.5	µA	
	I _{CC2}	Idle	-	90	150	µA	
Transmitter	Transmitter Wakeup Time	T _{tw}	-	15	20	µs	
	Viewing Angle	2θ _{1/2}	30	-	60	deg.	
	Data Output Pulse Width	T _{stp} w	tpw(RxD)=1.63µs at 115.2kbit/s	1.5	1.7	1.8	µs
	Rise Time	t _r	BR=115.2kbit/s	-	50	100	ns
	Fall Time	t _f	BR=115.2kbit/s	-	100	150	ns
	Peak Emission Wavelength	λ _p	-	-	875	-	nm
	Spectral Bandwidth	Δλ	-	-	45	-	nm
Receiver	Viewing Angle	2θ _{1/2}	30	-	-	deg.	
	Peak Sensitivity Wavelength	λ _p	-	880	-	nm	
	High Level Output Voltage	V _{OH}	I _{OH} =-200µA	2/3V _{CC}	-	V _{CC}	V
	Low Level Output Voltage	V _{OL}	I _{OL} =200µA	-	-	1/3V _{CC}	V
	Rx SIR Pulse Width	T _{srp} w	tpw(RxD)=1.63µs at 115.2kbit/s	1.4	2.2	4	µs
	Rise Time	t _r	BR=115.2kbit/s	-	50	100	ns
	Fall Time	t _f		-	50	100	ns
	Communication Distance	D		20	60	-	cm
	Receiver Latency Time	TL		-	60	200	µs
Receiver Wakeup Time	T _{rw}		-	50	100	µs	