

KOI-6001C

Features

- Compliant to IrDA 1.4 Low Power Standard
- Wide Voltage Operation : 2.7 ~ 5.5V
- Compact Package Integrated Transmitter and Receiver (8.0L x 2.75W x 2.5T)
- Complete Power Down Mode for the Current Consumption.
- Shielded Package for Preventing EMI
- LED Stuck-high Protection
- Lead-free & High reliability package

Applications

- Cellular Phone
- Personal Computer(Desk-top PC, Lap-top PC)
- Printers, Vending Machine, ATM
- Personal Digital Assistants.(PDA)

Dimensions

(Unit : mm)

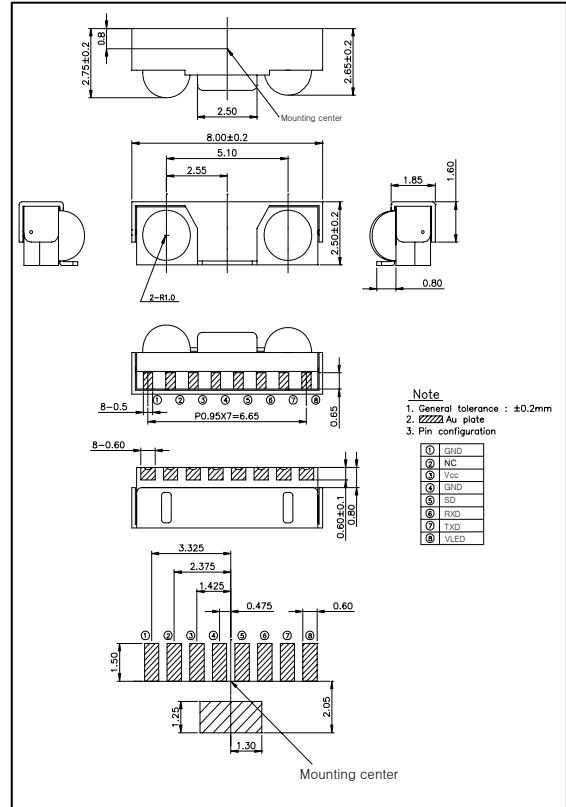

Block Diagram

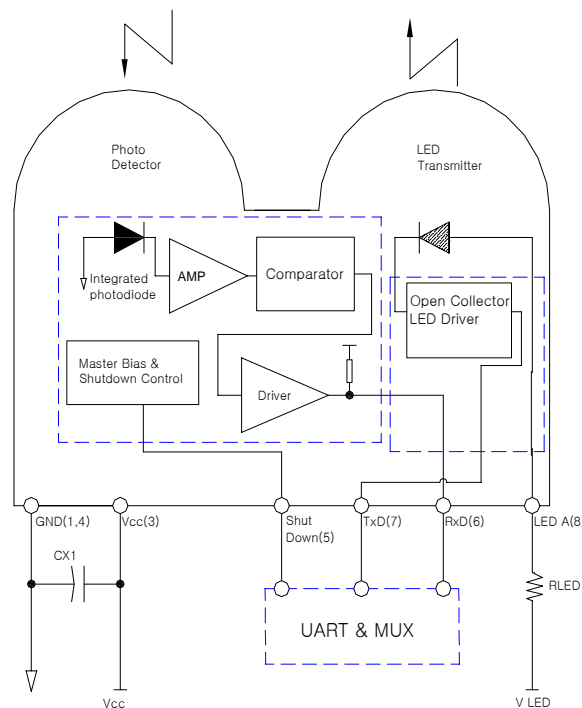

KOI-6001C

Absolute Maximum Ratings

[Ta = 25°C]

Parameter	Symbol	Conditions	Min.	Max.	Unit
Supply Voltage	V _{CC}	-	0	6.5	V
LED Supply Voltage	V _{LED}	-	0	6.0	V
Operating Temperature	T _{opr.}	-	-20	85	°C
Storage Temperature	T _{stg.}	-	-40	100	°C
DC LED Transmit Current	I _{LED (DC)}	-	-	50	mA
Peak LED Transmit Current	I _{LED (PK)}	<90µs pulse width, <20% duty cycle	-	200	mA
Receiver Data Output Voltage	V _{RxD}	-	-0.5	V _{CC} +0.5	V
Transmitter Data Input Voltage	V _{TxD}	-	-0.5	V _{CC} +0.5	V
Data Rate	BR	-	9.6	115.2	kbit/s

4. Electro-Optical Characteristics

[Ta=25 °C , V_{CC}=3.3V]

Parameter	Symbol	Conditions	Min.	Typ.	Max.	Unit	
Supply Current	I _{cc1}	Shutdown	-	-	1	µA	
	I _{cc2}	Idle	-	110	200	µA	
Transmitter	Transmitter Wakeup Time	T _{tw}	-	30	200	µs	
	Viewing Angle	2θ _{1/2}	30	-	60	deg.	
	Data Output Pulse Width	T _{stp} w	tpw(RxD)=1.63µs at 115.2kbit/s	1.5	1.7	1.9	µs
	Rise Time	t _r	BR=115.2kbit/s	-	80	200	ns
	Fall Time	t _f		-	80	200	ns
	Peak Emission Wavelength	λ _p	-	-	875	-	nm
	Spectral Bandwidth	Δλ	-	-	45	-	nm
Receiver	Viewing Angle	2θ _{1/2}	30	-	-	deg.	
	Peak Sensitivity Wavelength	λ _p	-	875	-	nm	
	High Level Output Voltage	V _{OH}	I _{OH} =-200 µA	2/3 V _{CC}	-	V _{CC}	V
	Low Level Output Voltage	V _{OL}	I _{OL} =200 µA	-	-	1/3 V _{CC}	V
	Rx SIR Pulse Width	T _{srp} w	tpw(RxD)=1.63µs at 115.2kbit/s	1.5	2.3	4.0	µs
	Rise Time	t _r	BR=115.2kbit/s	-	85	200	ns
	Fall Time	t _f		-	85	200	ns
	Communication Distance	D		20	60	-	cm
	Receiver Latency Time	TL		-	100	150	µs
Receiver Wakeup Time	T _{rw}		-	150	200	µs	